

PNL10-12SA Non-isolated Series

Features

- Point of load(POL) applications
- High efficiency: 94%, 5V/8A out
- -40 to +85 ambient operating temperature
- Open frame SIP
- 1.2Vdc to 5.5Vdc output for suffix "W" and 0.8Vdc to 1.8Vdc output for suffix "L"
- Output ON/OFF inhibit
- Auto-track sequencing
- Margin up/down controls
- Output voltage sense function
- RoHS compliant

Environmental

- Operating board temperature range:
-40°C to 100°C
- Storage temperature:
-55°C to 125°C
- Temp.coefficient:
$\lt; \pm 0.02\%/^{\circ}\text{C}$
- MTBF:
>2 million hrs

Electrical Specifications

Input

Input range: 10.8-13.2Vdc
Input under-voltage shutdown: 8.9-9.7Vdc

Output

Voltage setpoint accuracy: $\pm 2.0\%V_o$ max.
Voltage adjust: 0.8V to 5.5V
Line regulation: 10mV max.
Load regulation: 10mV max.
Over-current protection: $>160\%I_o$, auto-recovery
Short-circuit protection: continuous, auto-recovery
Ripple and noise: $<40\text{mVpp max. } V_o < 2.5\text{V}</math>
 $<1.5\%V_o \text{ Vpp max. } V_o \geq 2.5\text{V}</math>
Transient response: recovery $<70\mu\text{s max.}</math>
110mV max.
(50% step load change from 50% I_o)
di/dt: 1A/ $\mu\text{S}$$$$

Control

Control voltage:
Positive logic
High =on 10 to 14Vdc
Low=off -0.2 to 0.8Vdc
Control current: 2mA max

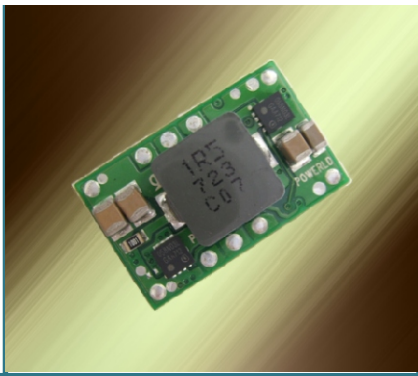

Ordering Information

Input Voltage	Output Voltage	Output Current	Efficiency	Model Number
10.8V to 13.2V	1.2V to 5.5V	10A	94%	PNL10-12SAW
10.8V to 13.2V	0.8V to 1.8V	10A	88%	PNL10-12SAL

Note: the above typical efficiency is acquired under the following condition,
 $I_o = 8A$; For "W", $V_o = 5V$; For "L", $V_o = 1.8V$

Dimensions

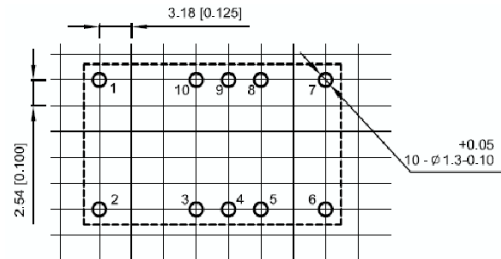
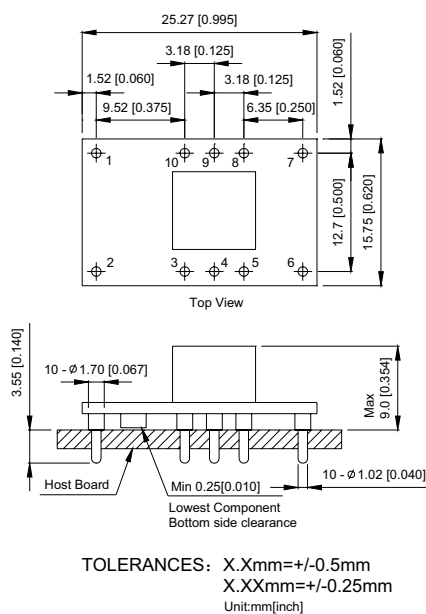

Pin Assignments

- | | |
|------|---------------|
| 1, 7 | GND |
| 2 | V_{in} |
| 3 | Inhibit |
| 4 | $V_o, adjust$ |
| 5 | $V_o, sense$ |
| 6 | V_{out} |
| 8 | Track |
| 9 | Margin down |
| 10 | Margin up |

Notes: The detail and recommended hole pattern layout is available in the Application Manual.

Output Voltage Programming

The Vo adjust control (pin 4) sets the output voltage of the PNL10-12SA product. The adjustment range is from 1.2 Vdc to 5.5 Vdc for the Suffix 'W' model and 0.8 Vdc to 1.8 Vdc for the Suffix 'L' model. To adjust the output voltage above 1.2 V, a single external resistor Rset must be connected directly between the Vo Adjust and GND pins. Table 1 and Table 2 give the preferred value for the external resistor for a number of standard voltages. For other output voltages the value of the required resistor can be calculated using the following equations.

$$R_{SET} = 10K \times \frac{0.8V}{V_{out} - 1.2V} - 1.82K\Omega$$

Equation 1 - 'W' Suffix Models

$$R_{SET} = 10K \times \frac{0.8V}{V_{out} - 0.8V} - 7.87K\Omega$$

Equation 2 - 'L' Suffix Models

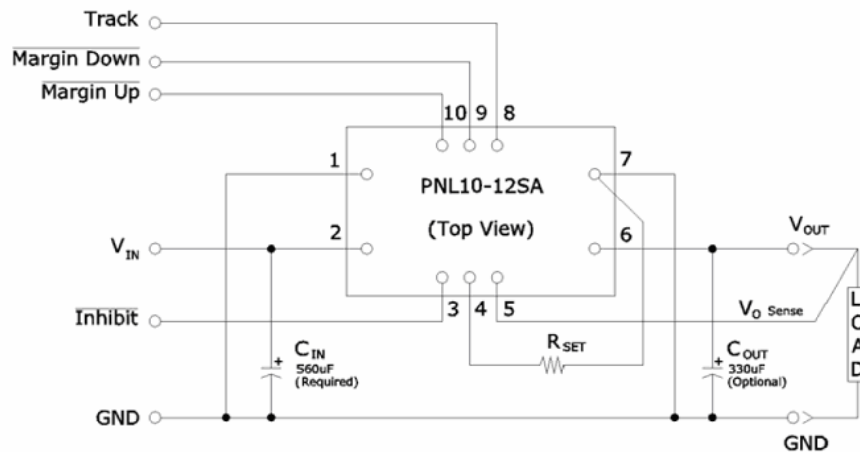

Figure 1 Circuit configuration for programming output voltage

R_{SET}: Adjust Resistor Placement

Vout Standard(V)	Rtrim(KΩ) (Preferred Value)
5.0	0.28
3.3	2
2.5	4.32
1.8	11.5
1.5	24.3
1.2	open

Table1: Preferred Values of Rset for Standard Output Voltages
'W' Suffix Models

Output Voltage Programming ---Continued

Vout Standard(V)	Rtrim(K Ω) (Preferred Value)
1.8	0.13
1.5	3.57
1.2	12.1
1.0	32.4
0.8	open

Table2: Preferred Values of Rset for Standard Output Voltages
'L' Suffix Models

Although the output voltage can be increased by both the remote sense and by the trim, the maximum increase for the output voltage is not the sum of both. The maximum increase is the larger of either the remote sense or the trim.

Note that at elevated output voltages the maximum power rating of the module remains the same, and the output current capability will decrease correspondingly.

Notes:

1. Use a 0.1 W resistor, with a tolerance of 1%, with temperature stability of 100 ppm/ $^{\circ}$ C (or better). Place the resistor as close to the regulator as possible. Connect the resistor directly between pins 4 and 7 using dedicated PCB traces.
2. Never connect capacitors from Vo Adjust to either GND or Vout. Any capacitance added to the Vo Adjust pin will affect the stability of the regulator.